

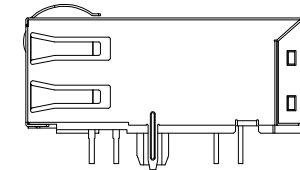

NOTES:

1. ROHS COMPLIANT
2. PLASTIC HOUSING: THERMOPLASTIC MATERIAL WITH FLAMMABILITY RATING UL 94V-0 OR BETTER.
3. CONTACTS PLATING: 50 MICRO-INCH GOLD PLATING.
4. CONTACTS BASE MATERIAL: PHOSPHOR BRONZE
5. UNDER PLATING: 30-50u INCHES NICKEL
6. SOLDER TAIL PLATING : 200-500 uINCHES 100% TIN, MATTE FINISH.
7. METAL SHIELD: NICKEL PLATING ON COPPER ALLOY.
8. JACK CAVITY CONFORMS TO FCC PART 68 SUBPART.
9. PCB PLATING: HASL
10. STORAGE TEMPERATURE: -20°C TO +125°C
11. COMPLIANCE TO J-STD:
 - A. J-STD-002: SOLDERABILITY AT 245°C DIP AND LOOK TEST
 - B. J-STD-020: LEVEL 1, NO MOISTURE SENSITIVE
 - C. J-STD-075: W2, 270°C MAXIMUM THROUGH WAVE SOLDER

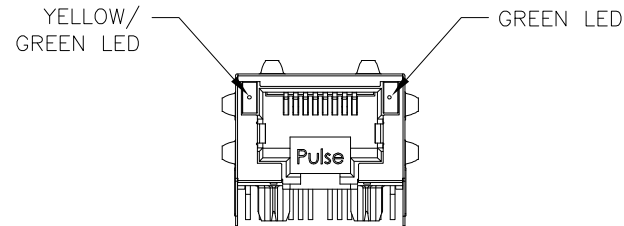
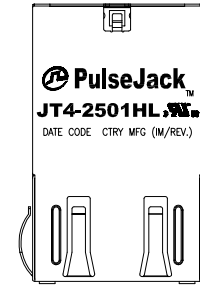

FINAL OUTLINE

© Copyright, 2017. Pulse Electronics Corp. All rights reserved. Pulse confidential & proprietary. (08/08/17)

PRODUCT DESCRIPTION	TLA DRAWING	PS DRAWING	SHEET	PART NO.	DATASHEET REV.
CONN,RJ45,1X1,2.5GD,1:1,TY	JT4-2501HL-P2	PS-2615.006-C	1 OF 5	JT4-2501HL	B



ELECTRICAL CHARACTERISTICS AT +25°C UNLESS OTHER SPECIFIED
MEETS IEEE 802.3 SPECIFICATION

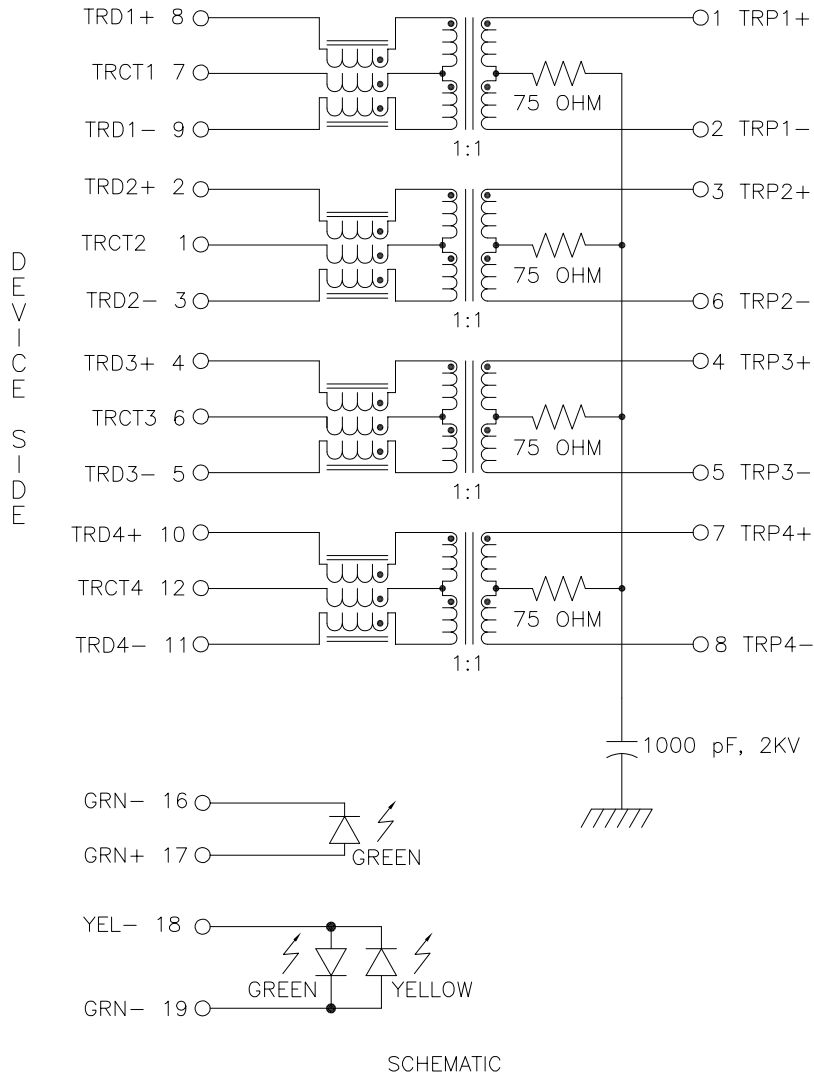

PARAMETER	SPECIFICATIONS	
OPERATING TEMPERATURE	0°C TO +70°C	
TURNS RATIO	1.00 ± 2%	
POLARITY	PER SCHEMATIC	
INSERTION LOSS (SDD21&SDD12)	1-50 MHz	50-125 MHz
	-0.5 dB MAX	-1.0 dB MAX
PHY-SIDE RETURN LOSS (SDD11 - Zref = 100 OHMS ± 1%)	1 MHz-40 MHz	40 MHz-200 MHz
	-20 dB MIN	-20+15*LOG ₁₀ (f/40) dB MIN
LINE-SIDE RETURN LOSS (SDD22 - Zref = 100 OHMS ± 1%)	1 MHz-40 MHz	40 MHz-200 MHz
	-20 dB MIN	-20+15*LOG ₁₀ (f/40) dB MIN
INDUCTANCE (OCL)	180 uH MIN @ 100 kHz, 100 mV	
CROSSTALK, ADJACENT CHANNELS (SDD21 - ADJ.)	1-25 MHz	25-125 MHz
	-40 dB MIN	-30 dB MIN
COMMON MODE REJECTION RATIO (SCC21)	1 MHz-200 MHz	
	-30 dB MIN	
COMM. TO DIFF. REJECTION RATIO (SDC12)	1 MHz-125 MHz	
	-45+f/35 dB MIN	
INPUT - OUTPUT ISOLATION	2250 VDC FOR 60 SECONDS	

NOTE: f IS FREQUENCY IN MHZ.

EMMITTED COLOR	GREEN	YELLOW	GREEN
WAVELENGTH (nm)	570	586	564-574
VIEWING ANGLE	120°	120°	150°
POWER DISSIPATION (Pd)	85 mW MAX	85 mW MAX	85 mW MAX
PEAK FORWARD CURRENT	120 mA MAX	80 mA MAX	120 mA MAX
FORWARD VOLTAGE (VF) @20mA	2.2 V TYP	2.2 V TYP	2.2 V TYP

NOTE: PER VENDOR'S SPECIFICATION

BICOLOR

© Copyright, 2017. Pulse Electronics Corp. All rights reserved. Pulse confidential & proprietary. (08/08/17)

PRODUCT DESCRIPTION	TLA DRAWING	PS DRAWING	SHEET	PART NO.	DATASHEET REV.
CONN,RJ45,1X1,2.5GD,1:1,TY	JT4-2501HL-P2	PS-2615.006-C	2 OF 5	JT4-2501HL	B

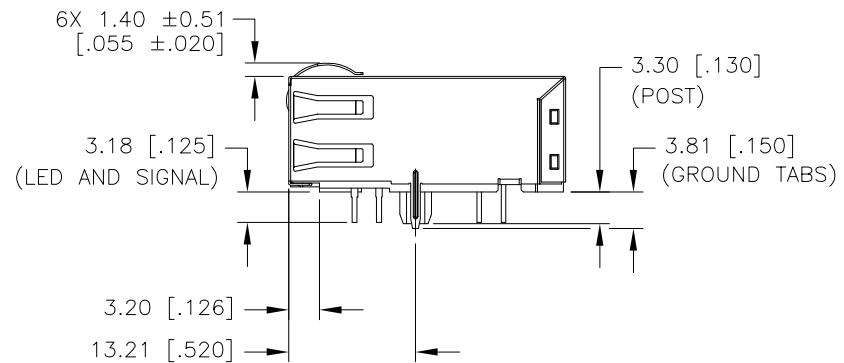
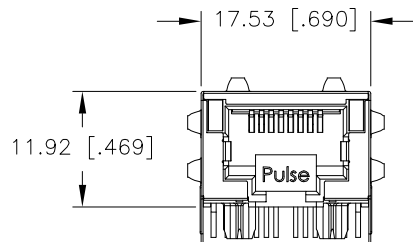
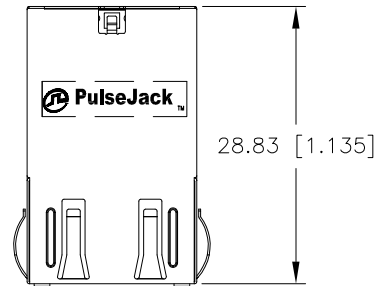

DIMENSIONS ARE IN MILLIMETERS [INCHES] WITH THE FOLLOWING TOLERANCES: [INCHES] ARE FOR REFERENCE ONLY.
X.XX [.XXX] = ±0.25 [±.010]

© Copyright, 2017. Pulse Electronics Corp. All rights reserved. Pulse confidential & proprietary. (08/08/17)

PRODUCT DESCRIPTION	TLA DRAWING	PS DRAWING	SHEET	PART NO.	DATASHEET REV.
CONN,RJ45,1X1,2.5GD,1:1,TY	JT4-2501HL-P2	PS-2615.006-C	3 OF 5	JT4-2501HL	B

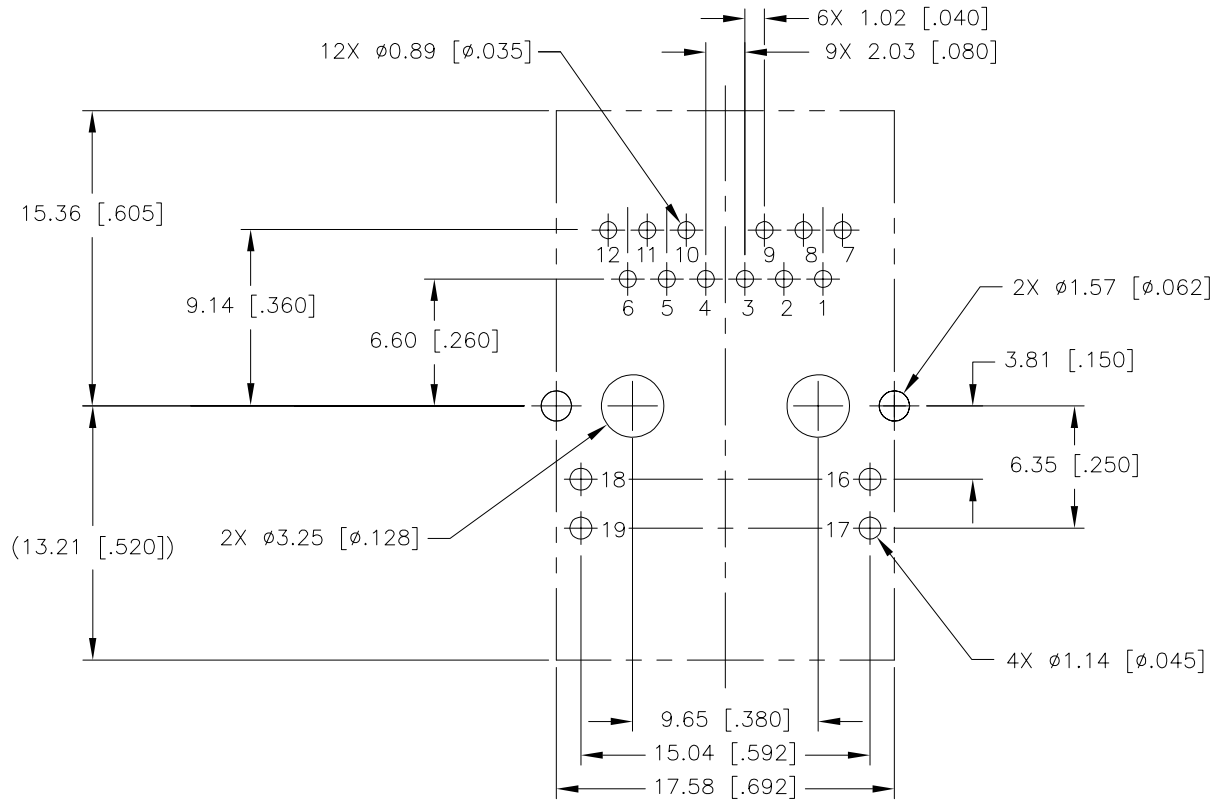

SUGGESTED FOOTPRINT (COMPONENT SIDE SHOWN)

DIMENSIONS ARE IN MILLIMETERS [INCHES] WITH THE FOLLOWING TOLERANCES: [INCHES] ARE FOR REFERENCE ONLY.
X.XX [.XXX] = ± 0.08 [± 0.003]

© Copyright, 2017. Pulse Electronics Corp. All rights reserved. Pulse confidential & proprietary. (08/08/17)

PRODUCT DESCRIPTION	TLA DRAWING	PS DRAWING	SHEET	PART NO.	DATASHEET REV.
CONN,RJ45,1X1,2.5GD,1:1,TY	JT4-2501HL-P2	PS-2615.006-C	4 OF 5	JT4-2501HL	B

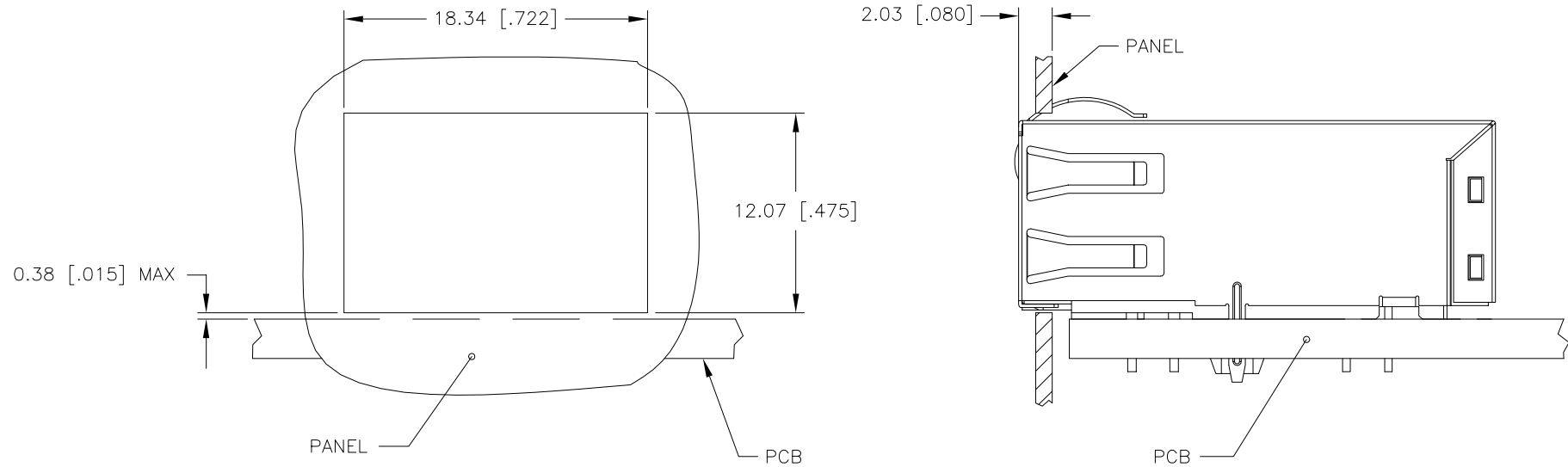

SUGGESTED PANEL CUTOUT

DIMENSIONS ARE IN MILLIMETERS [INCHES] WITH THE FOLLOWING TOLERANCES: [INCHES] ARE FOR REFERENCE ONLY.
X.XX [.XXX] = ± 0.10 [± 0.004]

© Copyright, 2017. Pulse Electronics Corp. All rights reserved. Pulse confidential & proprietary. (08/08/17)

PRODUCT DESCRIPTION	TLA DRAWING	PS DRAWING	SHEET	PART NO.	DATASHEET REV.
CONN,RJ45,1X1,2.5GD,1:1,TY	JT4-2501HL-P2	PS-2615.006-C	5 OF 5	JT4-2501HL	B