

# Isolation Power Transformers

Toroid Platform SMD

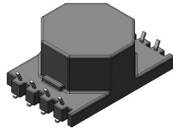

- ④ Push Pull Converter Transformer
- ④ 4.4kVrms Isolation (Up to 1500Vpk voltage rating)
- ④ Reinforced Insulation: IEC62368-1/UL62368-1 Certified
- ④ 22mm Creepage and Clearance
- ④ Footprint: 29.1 x 20x12.5 mm max

## Electrical Specifications @ 25°C - Operating Temperature -40°C to +85°C

Part Number	Inductance (1-2) (uH Min)	Leakage Inductance (1-2 shorted other pins) (uH MAX)	DCR (1-2) (3-4) (mohm MAX)	DCR (5-6) (7-8) (mohm MAX)	E*T(1-4) <sup>1</sup> (V*uSec Max)	Turns Ratio (1-4):(8-5) ±3.0%	Hi-Pot Voltage (Vrms)
PGT6541NLT	25	0.6	100	200	34	1:1.78	4400

### Notes:

1. The E\*T rating limits the peak flux density to 2100 gauss (flux swing 4200 gauss). When used in bipolar drive applications.
2. The applied ET may need to be further derated for higher frequencies based on the temperature rise which results from the core and copper losses
  - A. To calculate total copper loss (W), use the following formula:  
Copper Loss (W)=I<sub>rms\_Primary</sub><sup>2</sup>\*DCR\_Primary+I<sub>rms\_Secondary</sub><sup>2</sup>\*DCR\_Secondary
  - B. To calculate total core loss (W), use the following formula:  
Core Loss (W)= (3.66E-10) \* (Frequency in KHz)<sup>1.78</sup> \* (55\*(ET/ET Max)<sup>2.53</sup>  
Where ET is the applied Volt Second, ET Max is the rated Volt Second for 55mT flux swing, Frequency 410KHz
3. C. To calculate temperature rise, use the following formula: Temperature Rise (°C)  
=140\*(Core Loss(W)+Copper Loss (W))
4. For Push-Pull topology, where the voltage is applied across half the primary winding turns, the ET needs to be derated by 50% for the same flux swing.
5. Creepage and clearance is in accordance with IEC 62368-1 for reinforced insulation to a working voltage 1250Vrms with reinforced insulation (for basic insulation to a working voltage of 1500Vrms) based on material group III, pollution degree 2, OVC II and 2000m altitude. PGT6541NLT has obtained CB certificate based on IEC62368-1 and UL certificate based on UL62368-1.
6. Rated voltage is based on a positive partial discharge test (discharge < 10pC), in accordance with IEC60664 for basic insulation. In an application which requires a reinforced insulation barrier, a rated voltage of 1200Vpk is defined and confirmed by partial discharge testing.

# Isolation Power Transformers

Toroid Platform SMD

## Mechanical

## Schematic

PGT6541NLT

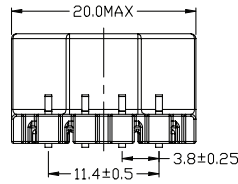
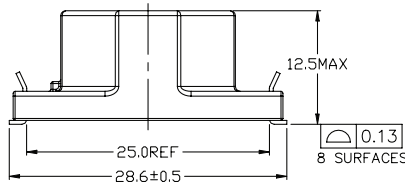
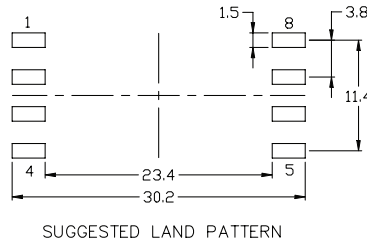
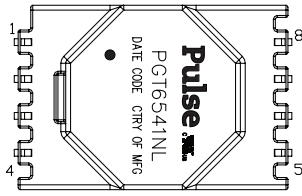

PUSH-PULL

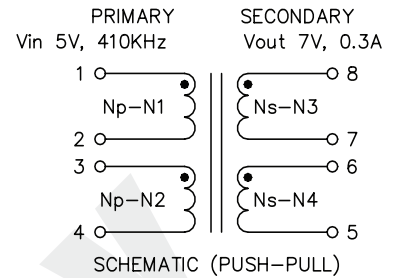

Weight .....1.6grams

Dimensions: mm  
Unless otherwise specified,  
all tolerances are ±0.25

## TAPE & REEL INFO

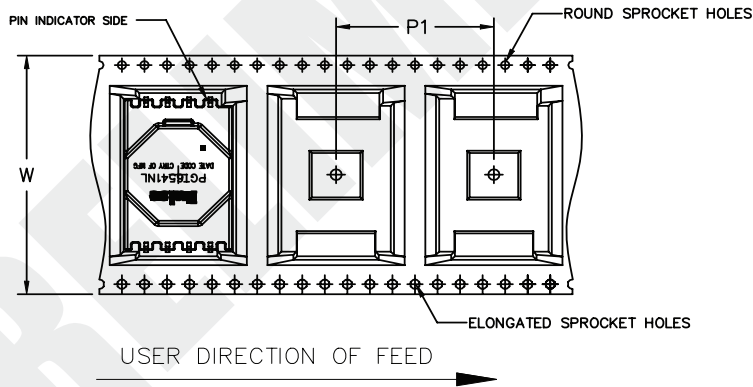

### SURFACE MOUNTING TYPE, REEL/TAPE LIST

PART NUMBER	REEL SIZE (mm)	TAPE SIZE (mm)			QTY
	A	P <sub>1</sub>	W	K <sub>0</sub>	PCS/REEL
PGT6541NLT	Ø330	28	44	12.7	150

### For More Information:

Americas - [proinfo\\_power\\_americas@yageo.com](mailto:proinfo_power_americas@yageo.com) | Europe - [proinfo\\_power\\_emea@yageo.com](mailto:proinfo_power_emea@yageo.com) | Asia - [proinfo\\_power\\_asia@yageo.com](mailto:proinfo_power_asia@yageo.com)

Performance warranty of products offered on this data sheet is limited to the parameters specified. Data is subject to change without notice. Other brand and product names mentioned herein may be trademarks or registered trademarks of their respective owners. © Copyright, 2023. Pulse Electronics, Inc. All rights reserved.

YAGEO Corporation and its affiliates do not recommend the use of commercial or automotive grade products for high reliability applications or manned space flight.

# Isolation Power Transformers

Toroid Platform SMD

## APPLICATION

PGT6541NLT is one high isolation power supply transformer drivers. Intended to operate in a fixed duty cycle Push Pull topology, it is a part of a low cost solution for delivering lower power (up to 3W) from a low voltage source. A typical implementation would be an isolated RS-485/RS-232 power supply driver circuit, the design is compatible with the SN6505NL.

A schematic diagram for the Push Pull converter topology is given below.

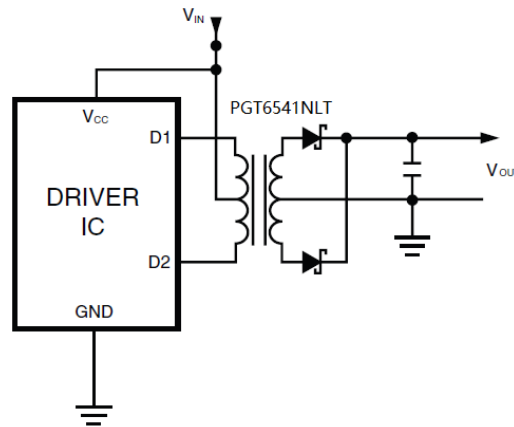

For a fixed 50% duty cycle mode of operation, the output voltage is simply determined by the input voltage and turns ratio. So, with the available turn ratios, a variety of output voltages can be met.

This transformer design has been certified by UL to comply with IEC62368-1:2018 with reinforced insulation for a working voltage up to 1500Vdc 22mm creepage and 4400VAC isolation voltage is guaranteed to meet this requirement. The design also complies with the Pulse's class F insulation system.

## For More Information:

Americas - [proinfo\\_power\\_americas@yageo.com](mailto:proinfo_power_americas@yageo.com) | Europe - [proinfo\\_power\\_emea@yageo.com](mailto:proinfo_power_emea@yageo.com) | Asia - [proinfo\\_power\\_asia@yageo.com](mailto:proinfo_power_asia@yageo.com)

Performance warranty of products offered on this data sheet is limited to the parameters specified. Data is subject to change without notice. Other brand and product names mentioned herein may be trademarks or registered trademarks of their respective owners. © Copyright, 2023. Pulse Electronics, Inc. All rights reserved.

YAGEO Corporation and its affiliates do not recommend the use of commercial or automotive grade products for high reliability applications or manned space flight.