

Sharkfin / Vehicular

5G-FR1+WiFi-6E/7+GNSS L1+L2 Direct Mount 7-in-1 Antenna

SKF5GEX74211DM - 617 to 7125 MHz



Features & Applications:

- 🌀 Vehicle roof mount, directly on metal plane
- 🌀 Ground plane independent
- 🌀 4x4 MiMo Cellular 5G-FR1 (4G compatible)
- 🌀 2x2 MiMo WiFi, DSRC, V2X (WiFi-6E/7 compatible)
- 🌀 Active GNSS L1+L2 with 28dB low noise amplifier
- 🌀 Heavy and light vehicles
- 🌀 IoT, navigation, tracking
- 🌀 Metering, EV charging stations
- 🌀 Request separately special cable length and connectors

ELECTRICAL SPECIFICATIONS

General Specifications – 5G FR1 + WiFi 6E/7

Antenna type	Nominal Impedance	Polarization	Radiation pattern	Power withstanding	DC Ground
Monopole ¹	50Ω	Vertical / Linear	Omni	45W	No

5G FR1 Antennas: 617 – 5925MHz

Port	Frequency (MHz)	617-960	1710-2700	3300-4200	4400-5000	5150-5925
Port 1, 2,3,4	Return Loss(dB)	-3	-4	-5	-5	-5
	Avg. Peak Gain (dBi)	2.3	4.6	5.2	5.7	4.4
	Avg. Efficiency (%)	40	54	52	49	50
Isolation ²	Isolation (dB)	7	10	20	20	25

WiFi 6E/7 Antennas: 2400-2500 / 4900-7125MHz

Port	Frequency (MHz)	2400-2500	4900-7125
Port 1,2,	Return Loss	-5	-5
	Avg. Peak Gain (dBi)	5.0	5.5
	Avg. Efficiency (%)	60	50
Isolation ²	Isolation (dB)	20	35

Notes:

1. Multi-Band Monopoles with built in ground plane, Independent from external ground plane
2. Minimum Isolation (dB)

ELECTRICAL SPECIFICATIONS

GNSS Antenna L1 Band: 1561.098 +/- 2.046MHz, 1575.42 +/- 1.023MHz, 1602.5625 +/- 4MHz

GNSS Antenna L2 Band: 1227.6 +/- 1.023MHz

Frequency (MHz)	L1 Band	L2 Band
Return Loss(dB)	< -8	< -10
Gain – Radiating Element (dBic)	2 +/- 1	4 +/- 1
LNA Gain (dB)	28 +/- 2	31 +/- 2
Polarization	RHCP	
Noise Figure (dB)	< 1.8	
Operating Voltage (V _{dc})	2.5-18	
Current Consumption (mA)	< 16	

MECHANICAL SPECIFICATIONS

SKF5GEX74211DM

Dimension (Length x Width x Height)	Housing Material	Color	Weight	Fixing System	Mounting Hole Diameter
400 x 52.5 x 63.8 mm (15.8 x 2.07 x 2.51 inch)	PC, UV Protected	Black	750g (1.22lbs)	Direct Mount	1.063" (27mm)
Wireless Technology	No. of Port	Cable Length	Cable Type	Connector Type	
5G FR1/ LTE	4	1ft (0.3m)	RG-316	SMA (Male)	
WiFi 6E/7	2	1ft (0.3m)	RG-316	SMA (Male)	
GNSS	1	1ft (0.3m)	RG-174	SMA (Male)	

ENVIRONMENTAL SPECIFICATIONS

SKF5GEX74211DM

Operating Temperature	Storage Temperature	RoHS Compliant	Ingress Protection
-40 / +85° C	-40 / +85° C	Yes	IP67

Sharkfin / Vehicular

5G-FR1+WiFi-6E/7+GNSS L1+L2 Direct Mount 7-in-1 Antenna

SKF5GEX74211DM - 617 to 7125 MHz

Mechanical Drawing

SKF5GEX74211DM

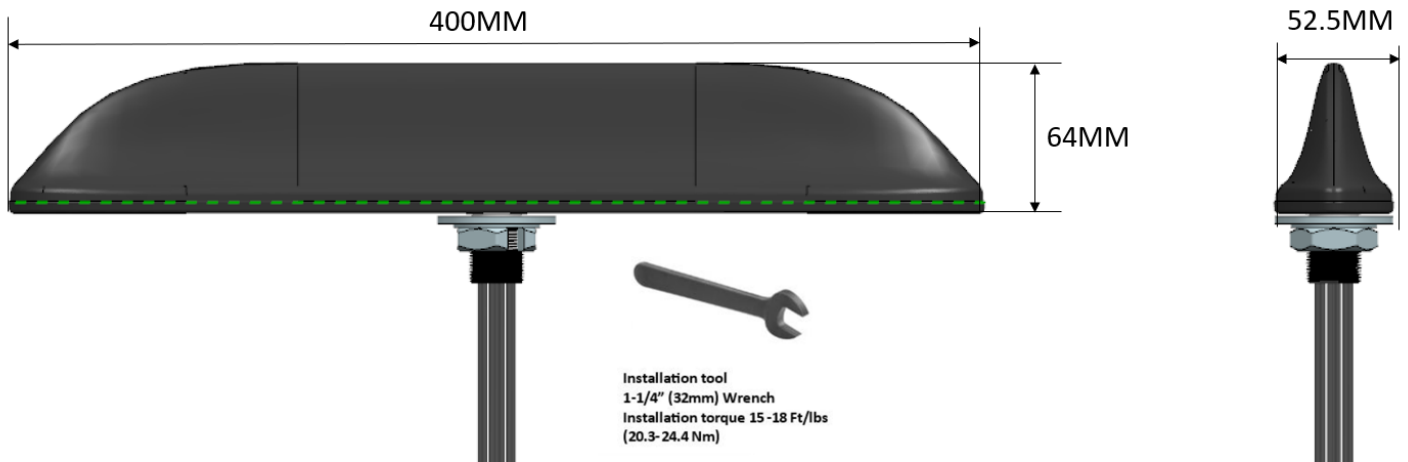

Dimensions: inches (mm) Unless otherwise specified, all tolerances are ± 0.010 (0.25mm)

RF Test setup

SKF5GEX74211DM

- All measurements done on $\varnothing 500\text{mm}$ (20") round ground plane.
- S-parameters with 0.3m RG 316 cable
- Gain and Efficiency with 0.3m RG 316 cable
- Measured at Pulse, Suzhou

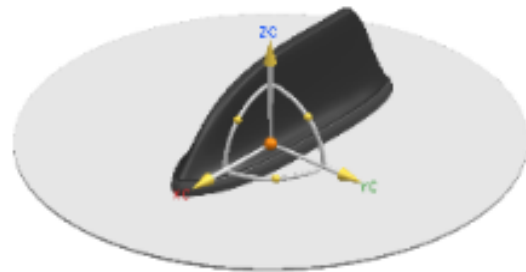

Charts – Return Loss, Efficiency, Peak Gain, Isolation

5G FR1

Return Loss vs Frequency

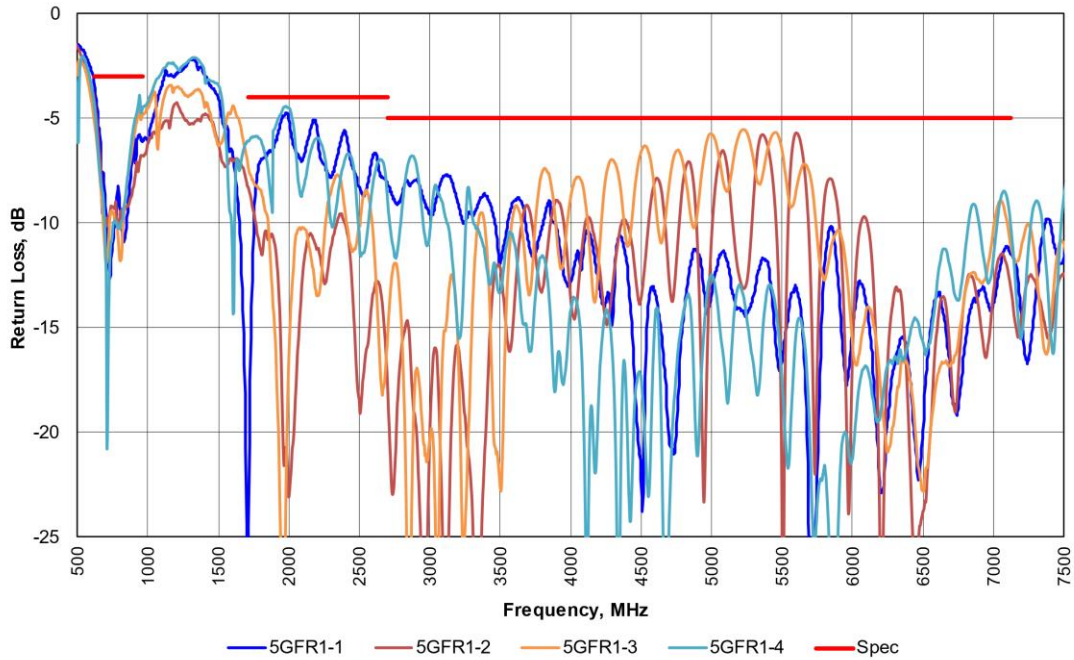

Efficiency vs Frequency

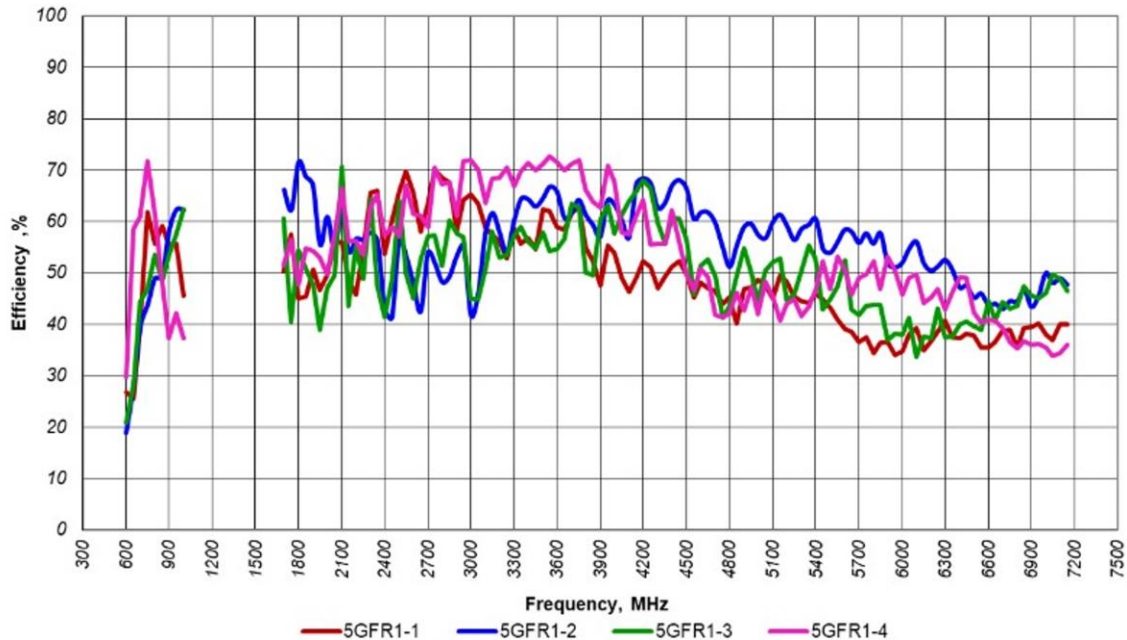

Peak Gain vs Frequency

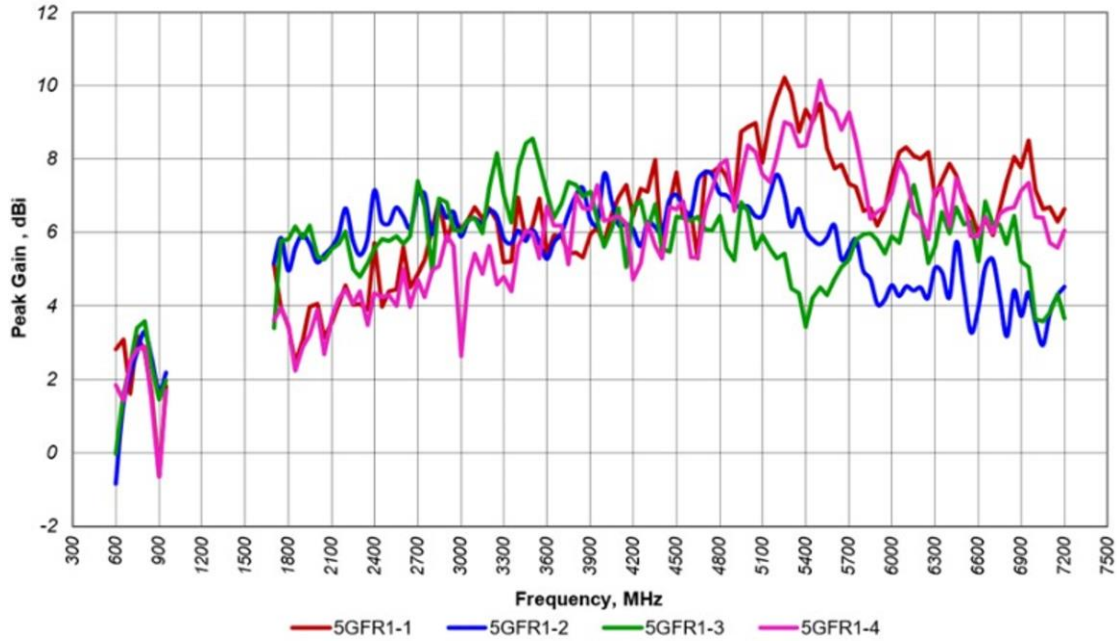

Isolation vs Frequency

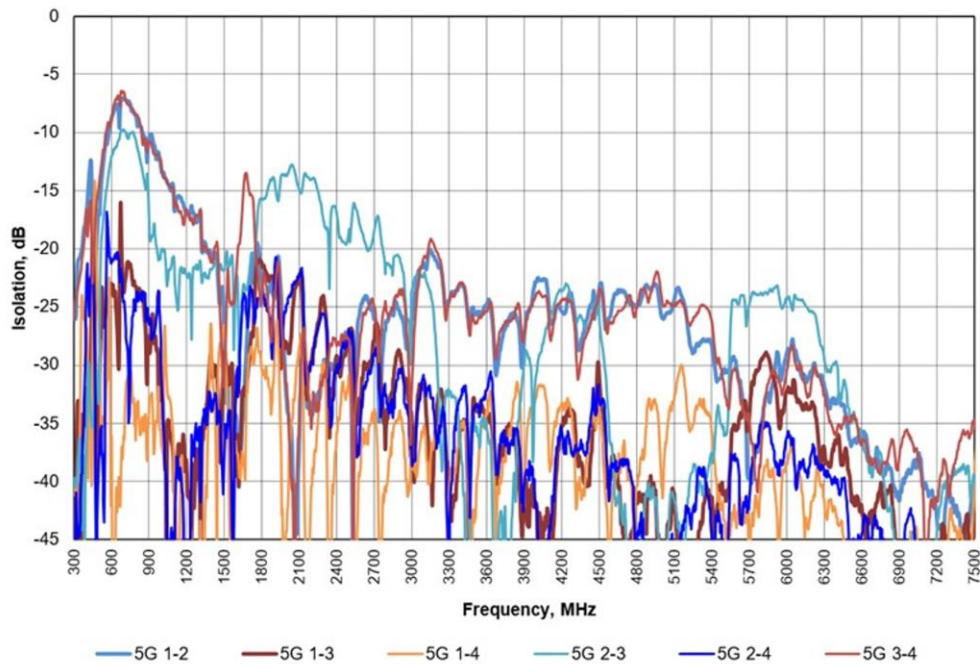

Charts – Return Loss, Efficiency, Peak Gain, Isolation

WiFi 6E/7

Return Loss vs Frequency

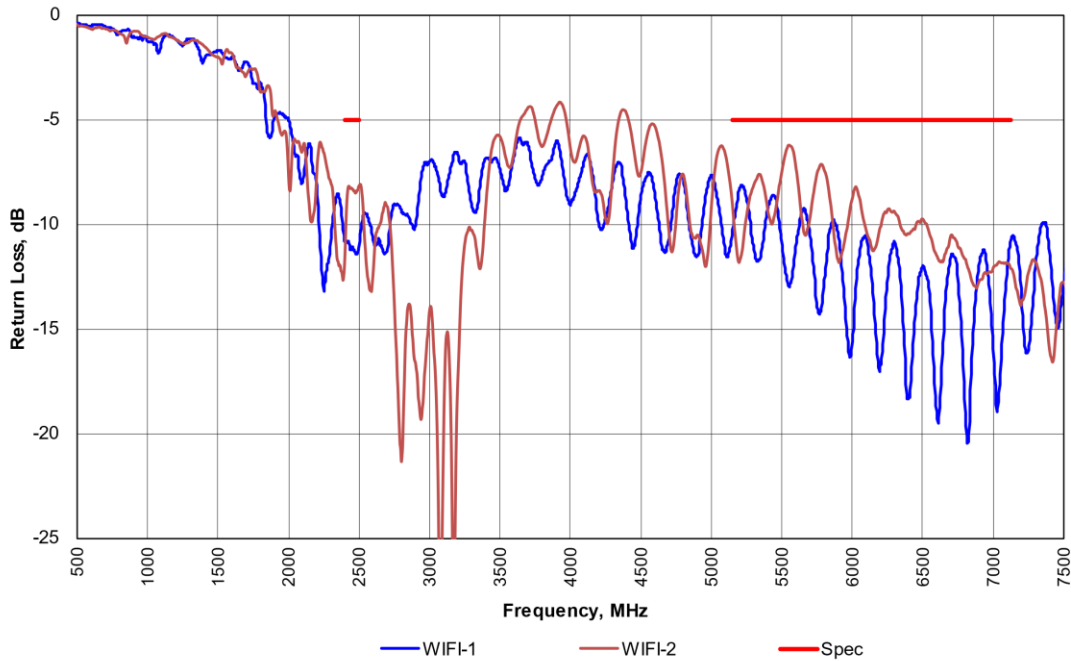

Efficiency vs Frequency

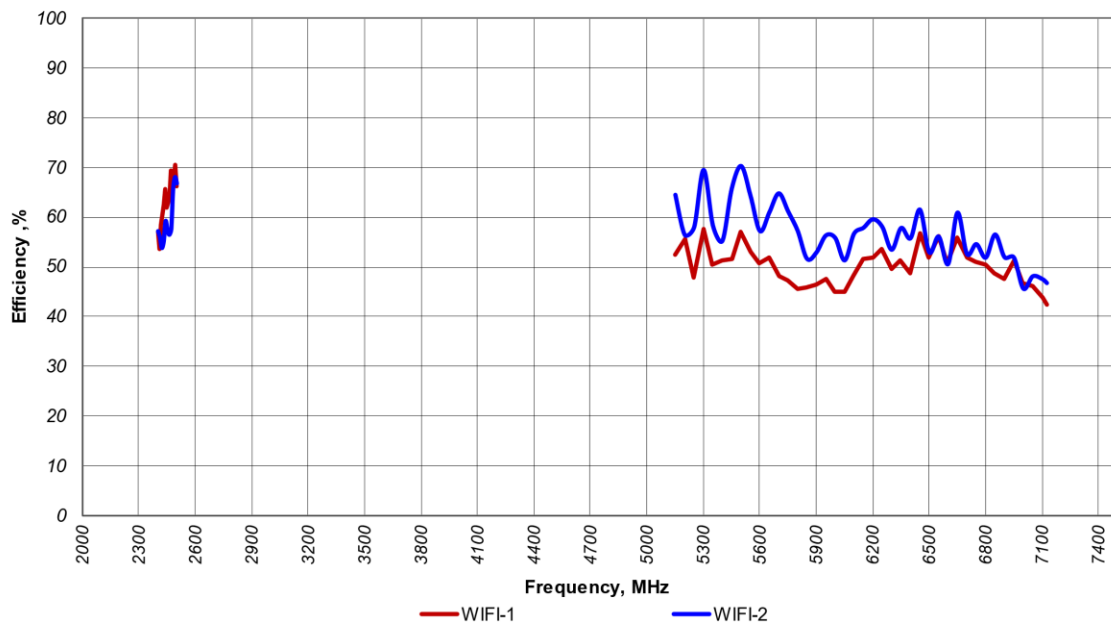

Peak Gain vs Frequency

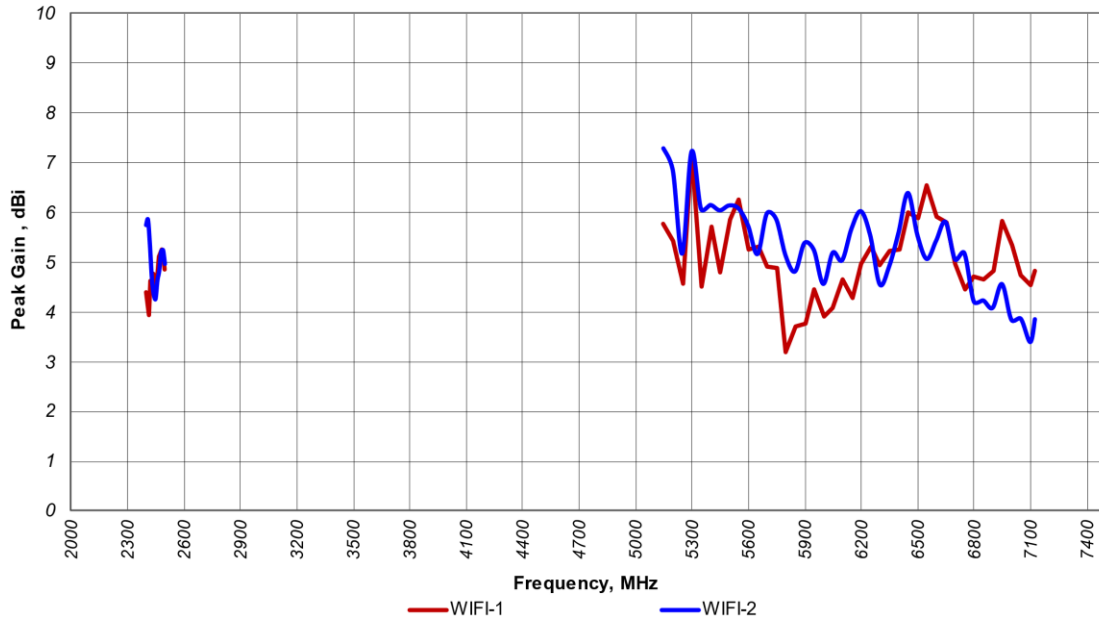

Isolation vs Frequency

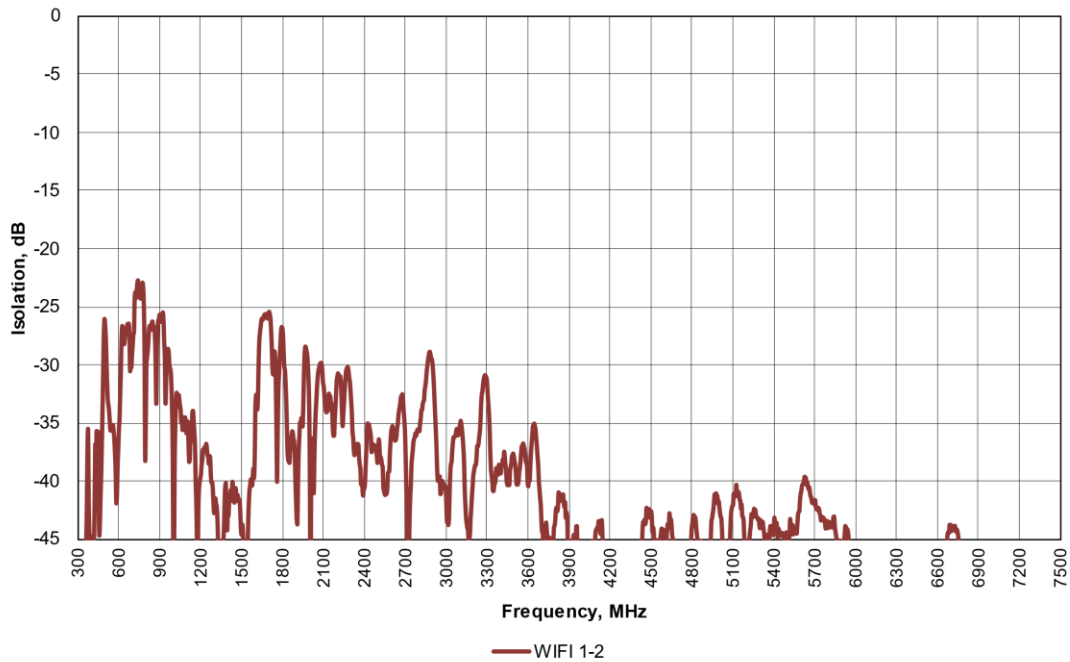

Charts- GNSS Antenna Return Loss, Efficiency, Peak Gain

GNSS

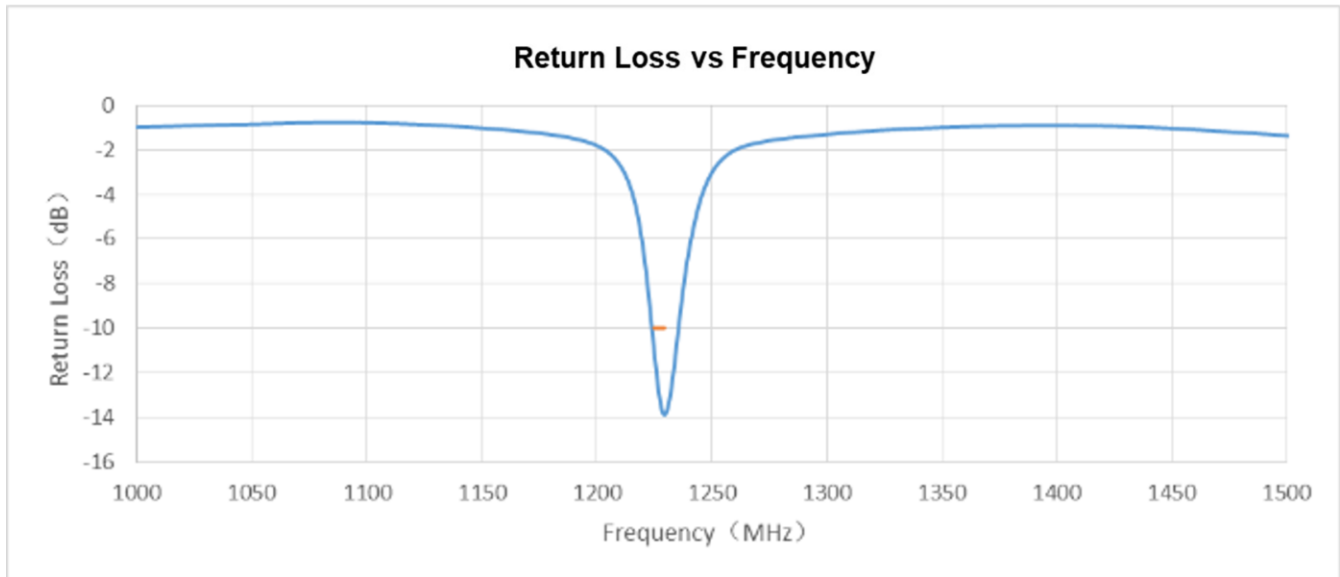
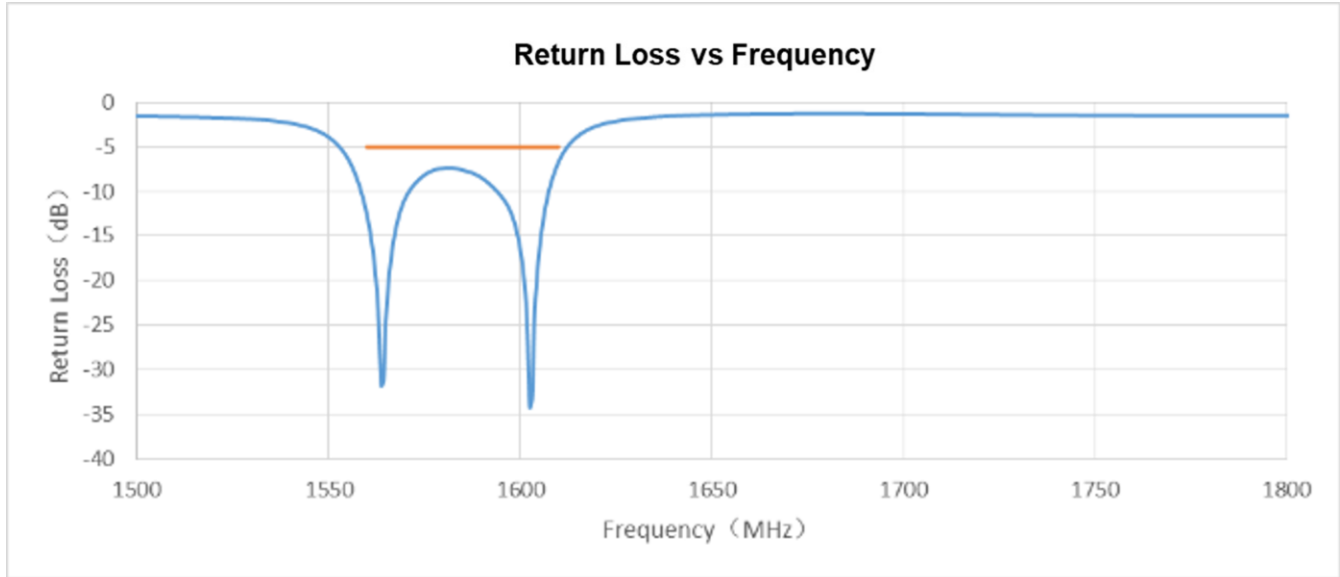

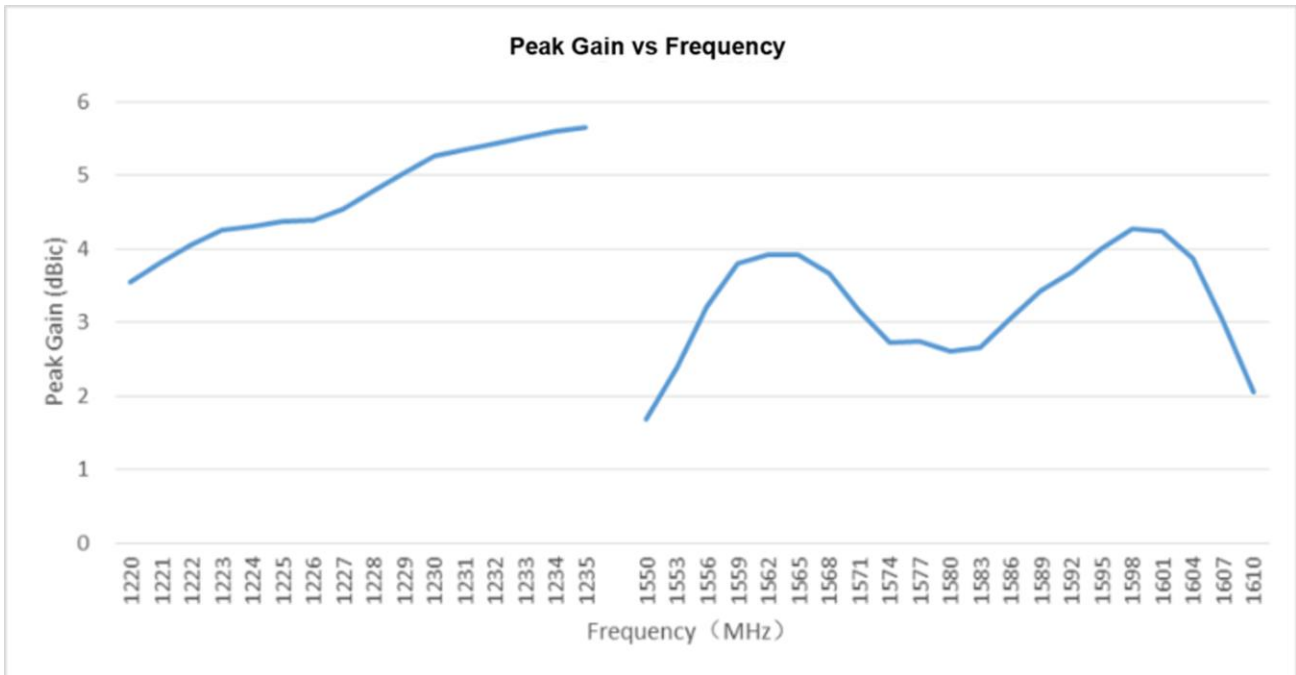
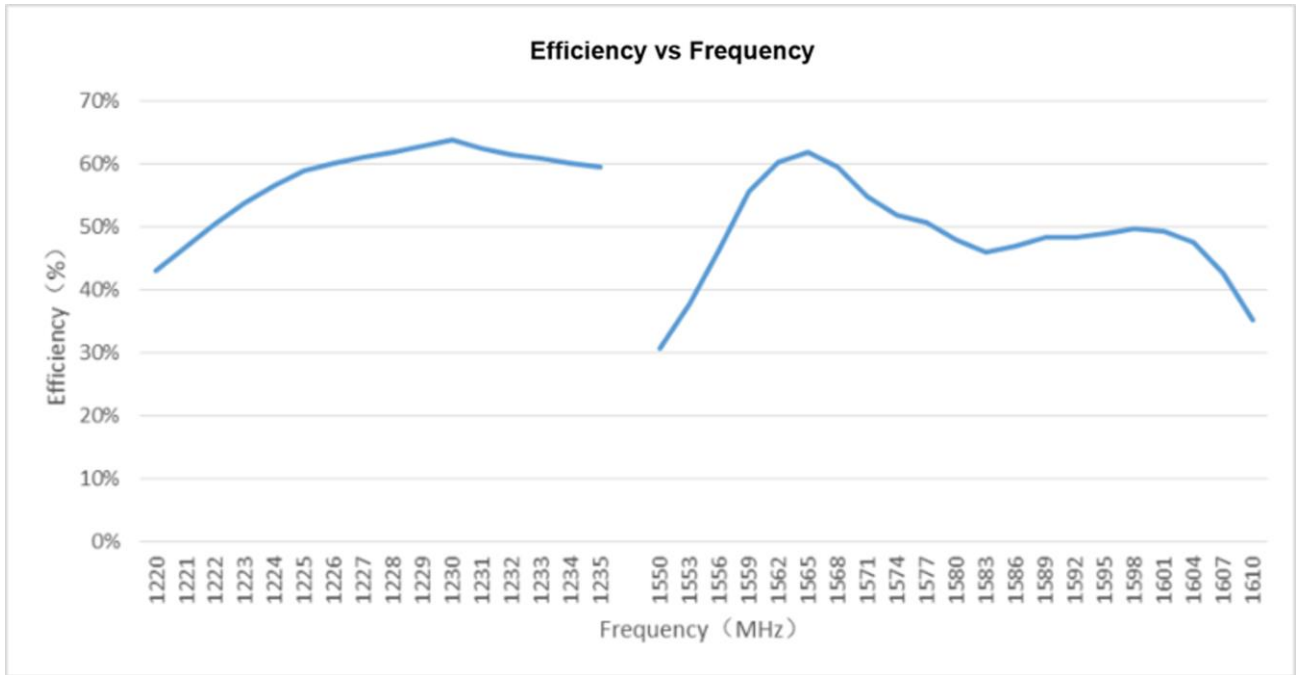

GNSS Antenna - LNA Gain

LNA gain and Out-of-band Rejection (L1)

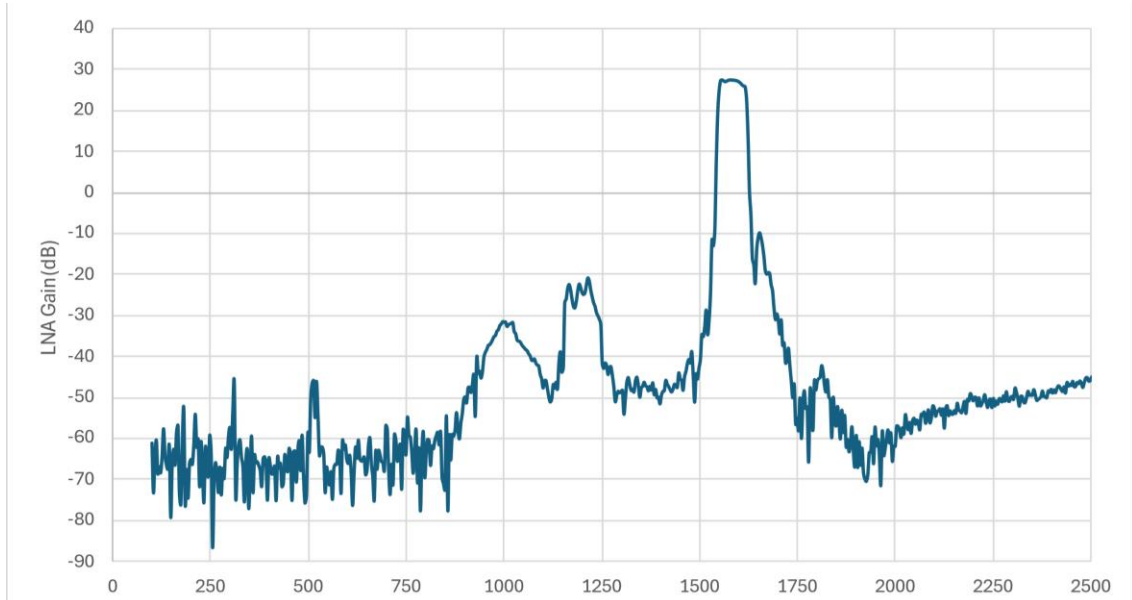

GNSS Antenna - LNA Gain

LNA gain and Out-of-band Rejection (L2)

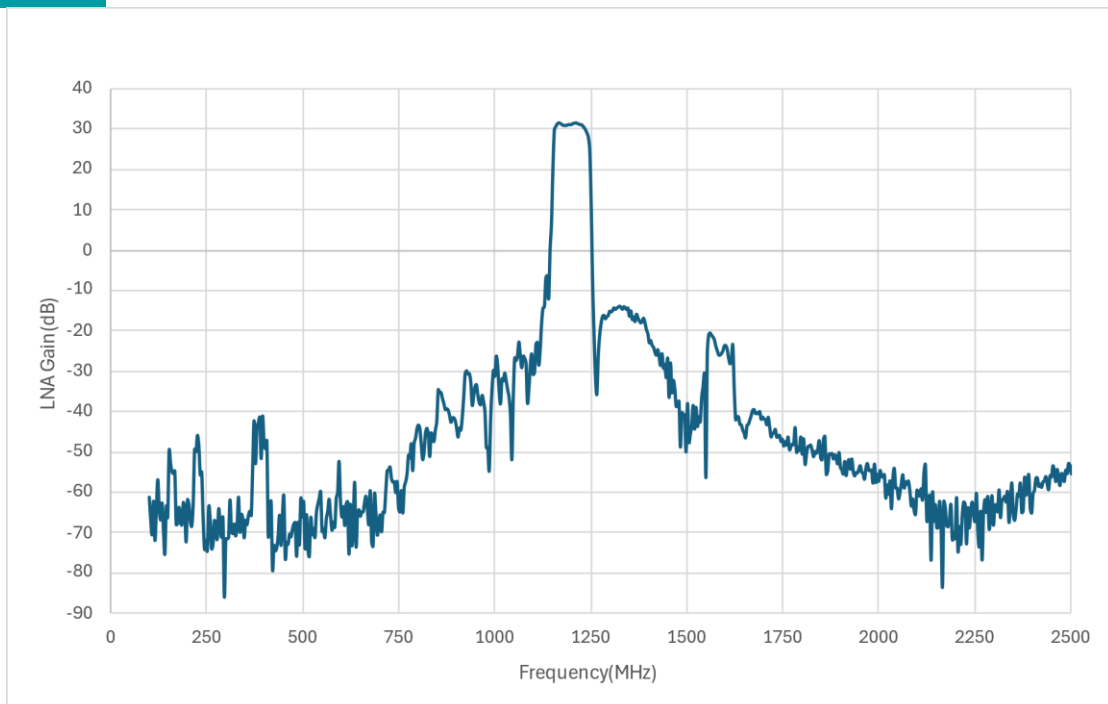

GNSS Antenna - Radiation Pattern (YZ Plane) Plots

YZ Plane: Passive measurement (L1)

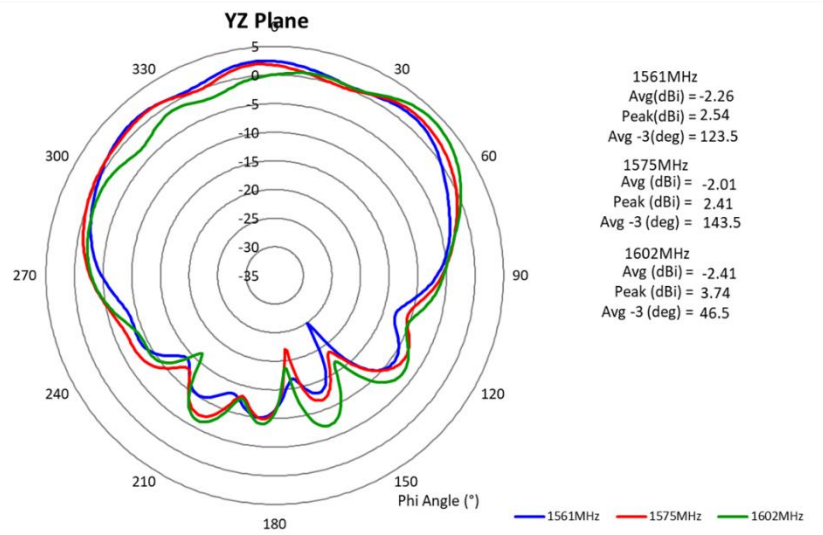
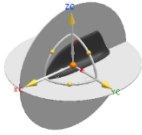

GNSS Antenna - LNA Gain and Radiation Pattern (YZ Plane) Plots

YZ Plane: Passive measurement (L2)

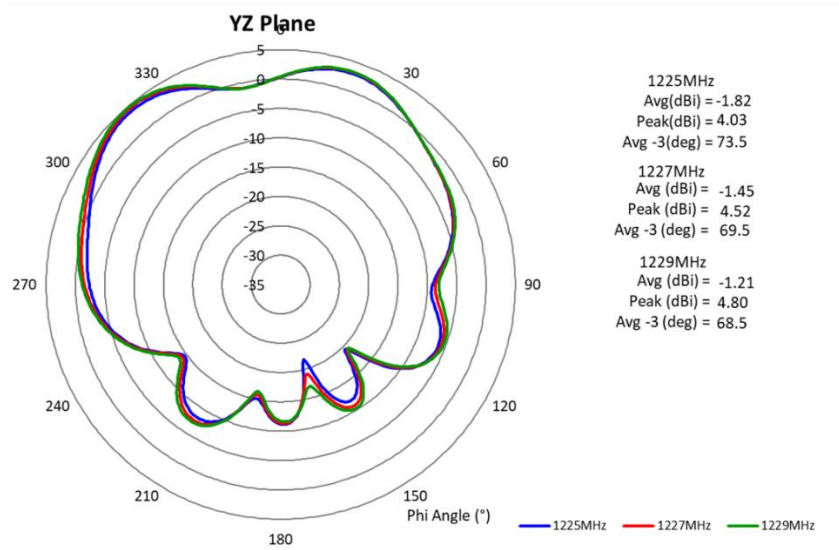
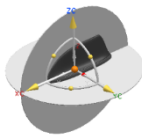

PACKAGING

SKF5GEX74211DM

1pcs antennas per plastic bag

Additional Product Info

Cable Assemblies for
 SKF5GEX74211DM (Not included)



TWC (Twin Castle) Cable Assemblies

SKD5GEX7 Cable Assemblies

Orderable P/N ¹	5G FR1 Port 1	5G FR1 Port 2	5G FR1 Port 3	5G FR1 Port 4	WiFi 6E Port 1	WiFi 6E Port 2	GNSS Port 1
SKF5GEX7-3M	SMA-M	SMA-M	SMA-M	SMA-M	RPSMA-M	RPSMA-M	SMA-M
SKF5GEX7-5M	SMA-M	SMA-M	SMA-M	SMA-M	RPSMA-M	RPSMA-M	SMA-M

Notes:

1. Please contact sales for availability, lead time, and/or any special requests. Samples available upon request.

For More Information:

Americas - antennas.us@pulseelectronics.com | Europe - antennas.eu@pulseelectronics.com | Asia - antennas.as@pulseelectronics.com | Questions? +1-800-ANTENNA
 Performance warranty of products offered on this data sheet is limited to the parameters specified. Data is subject to change without notice. Other brand and product names mentioned herein may be trademarks or registered trademarks of their respective owners. © Copyright , 2020. Pulse Electronics, Inc. All rights reserved.
 Company address: Pulse Electronics, a YAGEO Company, 15255 Innovation Drive, Suite #100, San Diego, CA 92128.

'YAGEO Corporation and its affiliates do not recommend the use of commercial, automotive, and/or COTS grade products for high reliability applications or manned space flight.'